



SUNWARM[®]

**Application and Installation Guide
for sunwarm system
(excluding Solar Air Collectors)**





Application and Installation Guide

for **sunwarm**[®] system
(excluding Solar Air Collectors)



Nuaire Limited Western Industrial Estate Caerphilly United Kingdom CF83 1NA
Telephone: 029 2085 8441 Facsimile: 029 2085 8442
Email: info@sunwarm.com www.sunwarm.com
Email: info@nuaire.co.uk www.nuaire.co.uk



Application and Installation Guide for Sunwarm System

Contents

Section 1

Pages 2 - 4 **Introduction**

Section 2

Pages 5 - 9 **Installation of the
3 part Air Handling Unit and
Associated Components**

Section 3

Page 10 **Installation of the
Solar Hot Water Storage System
and Associated Components**

Section 4

Pages 11 - 12 **Electrical Connections**

Section 5

Pages 13 - 15 **Commissioning the System, Checklist**

Section 6

Page 16 **Dimensions of System Components**

Section 7

Page 17 **Maintenance**

Section 8

Page 17 **Warranty**

Section 9

Page 17 **Service Enquiries**

Section 10

Pages 18 - 19 **Certification**

Section 11

Page 17 **NICM**

Section 12

Page 20 **System Registration**

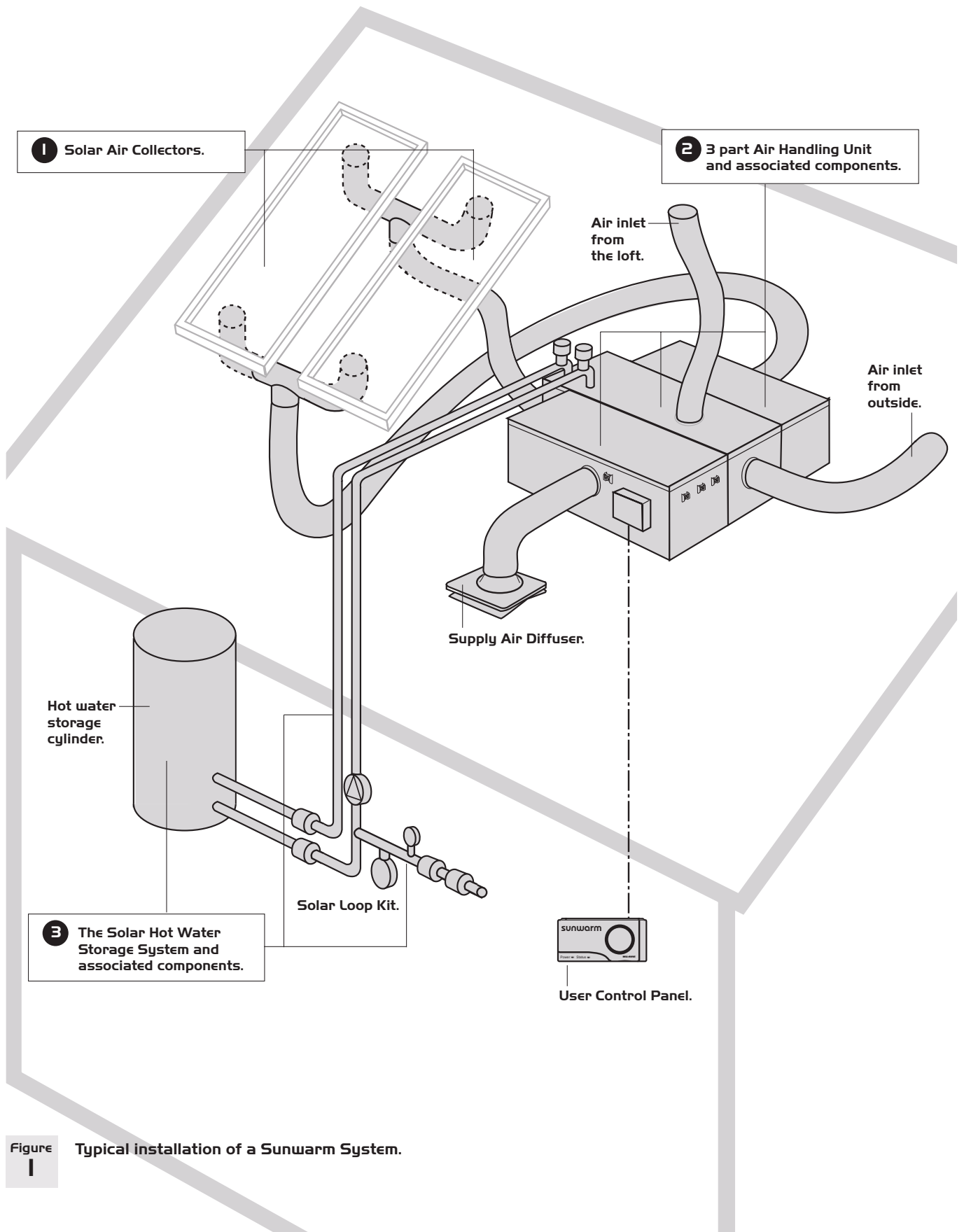

Figure 1 Typical installation of a Sunwarm System.

I.1 Important Notes to Designers and Installers

The successful operation of the system depends entirely upon it being applied, installed and maintained strictly in accordance with these instructions.

Please read through this guide in its entirety before commencing works and then follow the instructions step by step to ensure satisfactory completion.

The installation works include connection to the mains electrical and water supplies and work at high level (roof). Depending on the hot water system employed in the building, the use of pressurised water vessels may be involved.

These items require - in some cases as a legal requirement - the employment of suitably qualified tradesmen.

Before commencing work the installer must ensure that he/she is familiar with all national and local requirements and that the installation team is able to comply with them.

Sunwarm System can be installed in a home with a “cold roof” or “warm roof”. These instructions are limited to installation in a home with a “cold roof”. “Warm roofs” vary considerably and advice should be sought from Nuairé or your authorised installer on an individual basis.

I.2 System

There are three main component groups to be considered when installing a Sunwarm system. Refer to figure I.

- ❶ The Solar Air Collectors.
- ❷ The 3 part Air Handling Unit and Associated Components.
- ❸ The Solar Hot Water Storage System and Associated Components.

Note: This manual covers items 2 and 3. For Collector installation instructions refer to manual number 671274, which can be downloaded from Sunwarm Website.

Please note that all systems are supplied with all necessary sensors and sensor cables required to operate the system (not shown on figure I)

Where hot water storage cylinder and solar loop kit are supplied by others they must be checked for compatibility with Nuairé. All installation materials not supplied as standard with the system e.g. ducting, pipework and fittings are normally supplied by the installer.

Please note Nuairé cannot accept responsibility for unsatisfactory performance of equipment it does not supply.

The installation instructions that follow are based on a complete system provided by Nuairé. Where hot water storage cylinder and/or solar loop kit are supplied by others for use with SUNWARM, then please refer to relevant manufacturers application, installation and maintenance instructions.



I.0 Introduction cont.

I.3 Installation Requirements

Before commencing installation, the following issues need to be addressed.

1) The 3 part Air Handling Unit will normally be mounted in the loft space. Please note the following regarding "cold roof" construction:

Check to ensure that the loft has adequate ventilation. Look for ridge vents, tile vents, eaves vents and continuous air gaps etc. making sure none are blocked. In older properties these vents may not be provided. However, there should be enough 'leakage' to accommodate the requirements of the unit. A useful way of checking such lofts is to close the hatch, switch off the lights and look for any daylight penetration. If you can see daylight it is reasonable to assume that the loft has sufficient ventilation.

There may be occasions where a loft is so well sealed that additional ventilation may have to be provided by the owner/occupier or the unit installer.

This will not only assist the operation of the unit, but will help prevent possible expensive structural damage caused by inadequate air movement in the loft itself.

It should be noted that there cannot be too much ventilation into the loft.

Additional checks should be carried out as follows:

- Ensure that all water tanks are covered and sealed.
- Check that all water pipes are lagged.
- Ensure that any extract fans are discharging to outside and not into the loft.
- Check that the loft hatch is tightly sealed.
- Ensure all holes in the ceilings are sealed i.e. ceiling light fittings etc.
- A visual inspection of flues or chimneys for leakage in the loft should be carried out by the installer. If leakage points are found, or if there is any doubt regarding the same, the installer should advise the house owner/provider and seek instruction from them before continuing with installation.
- The unit must be able to pass through the loft access (minimum dimensions required are 555 x 370 mm).

2) The Water Storage cylinder must be located in an area that can accommodate the mass of water held - typically 250kg.

I.4 General Installation

The process to be followed will generally be as shown below :-

- Install Solar Air Collectors.
- Install 3 part Air Handling Unit.
- Install all ductwork and temperature sensors.
- Install hot water cylinder and associated components.
- Complete all electrical installation work.
- Test and commission.

On new buildings, the installation may be phased in line with the building construction.

I.5 Before Beginning Installation

1) Make sure you have received all items listed under the packing list. (see below).

2) Make sure you have all necessary ducts and duct fittings.

3) Make sure you have all necessary plumbing pipes and fittings.

4) Make sure you have all the necessary health and safety equipment needed.

Sunwarm Packing List

Description:	Part No.	Quantity
Thermister Bead + cable (14m)	240329	4
IOK Thermister Lead and 15mm Pipe	240346	2
Sunwarm User Control	774143	1
Sunwarm Sensor Housing	774598	1
Pump Control Box	774619	1
Sunwarm Diffuser Kit	774982	1
Low Voltage Cable	SCBL-10	3
Installation Manual	671275	1
User Guide	671230	1
T Pieces	TP x200	2
VI Master		1
VI Slave		1
CB Coil Box		1

2.0 Installation of the 3 part Air Handling Unit and Associated Components

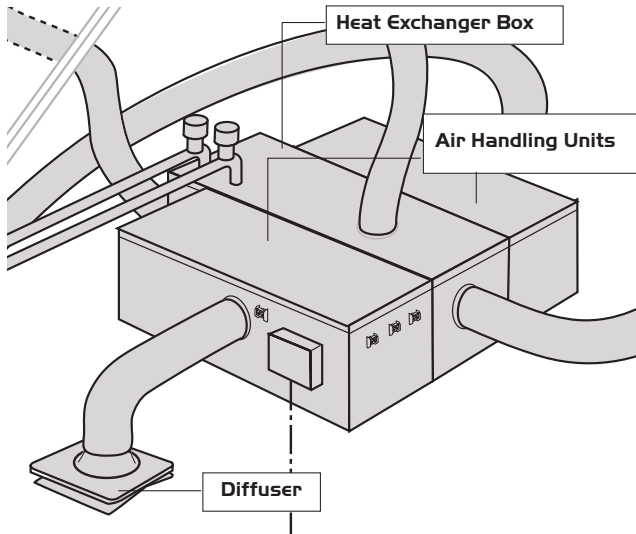

2.1 Positioning the Units

Position the units over a suitable board on the floor of the loft in a convenient place to reduce the length of ductwork and pipe run. (See figure 2).

Ensure that access for further installation work and for future maintenance is maintained.

The filter access panels on top of each Air Handling Unit **MUST** be positioned to allow removal of the filters, approximately 500mm of free space is required above the unit top face.

The Air Handling Units are marked as “master” and “slave”. Make sure the units are connected in accordance to their marking (see figure 2).

2.2 Connecting Air Handling Units

Position the Master Unit on the board. Slide the air-to-water heat exchanger box until the spigots and the holes match up. Slide the slave unit until the spigots match to the holes. Push all three boxes together. Secure the boxes by using the two rectangular brackets with four screws each on the flush side. Use the other “L” shape brackets with four screws each and secure the other side of the boxes, as shown in figure 2.

2.3 Ductwork Connections

Figure 3 shows detail of the duct connections at the various system locations. This layout minimises the quantity of ductwork required.

If the loft layout dictates an alternative arrangement, it is important that the ductwork connections are made as shown.

Install the spigots supplied to inlet and outlet holes of each collector using the self tapping screws provided. Make sure that the one spigot with pre-connected sensor is used for one of the outlets.

Insulated ductwork must be used where indicated. Ductwork connections should be securely made using “Dynotie” zip ties and sealed with at least 40 micron aluminium adhesive tape/duct tape.

Make sure you connect all sensors before connecting the ductwork securely.

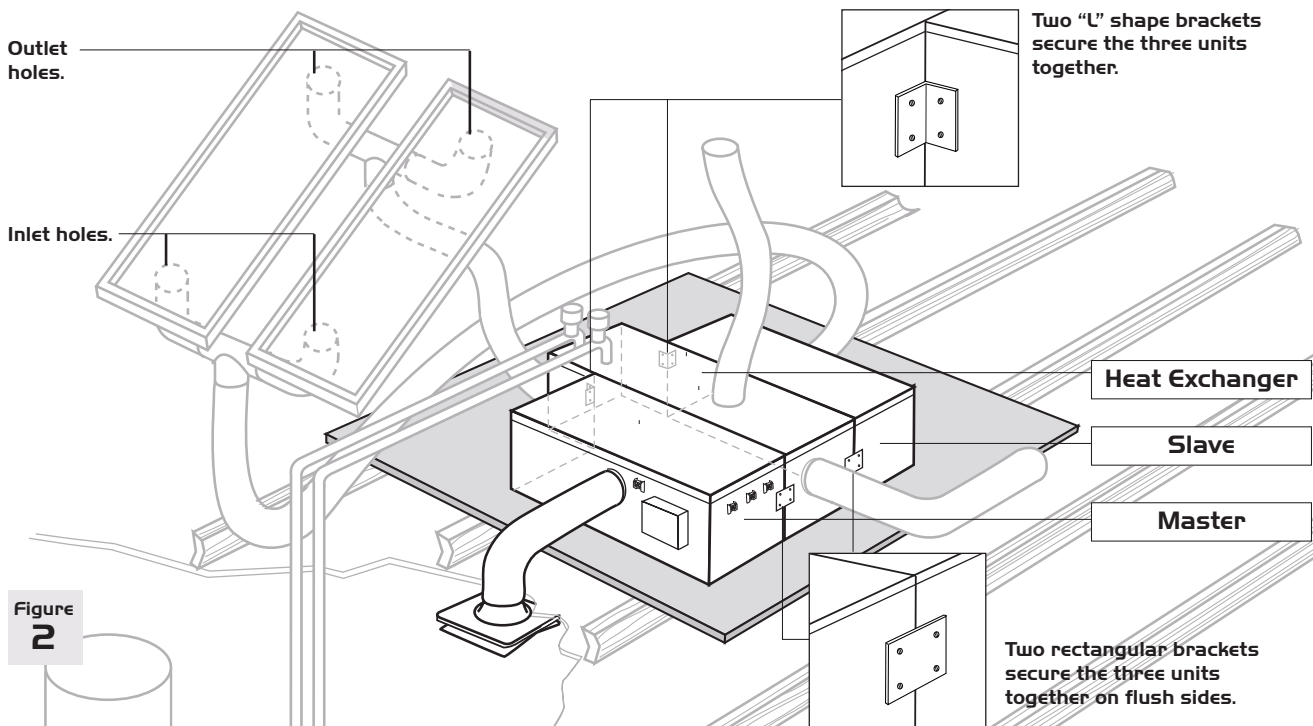

Figure 2

2.0 Installation of the 3 part Air Handling Unit and Associated Components

Figure 3

Air inlet via the loft space at high level

through uninsulated ducting supplied by the installer

200mm dia. uninsulated duct (min 1.5m extended) secured to roof timber using large washer and screw (supplied by installer) inside throat of duct. Ideally the inlet to the duct should be located approximately 600mm down from the highest point in the loft.

Note: the ducting may be turned through 90° to obtain the minimum 1.5m extended length.

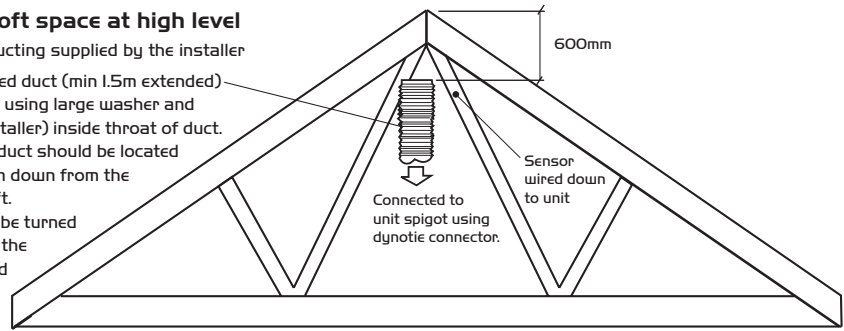

Duct section A is not supplied with unit. Must be 200mm Ø insulated.

These ducts are not supplied with unit. Must be 200mm Ø insulated.

Pull duct over T pieces as far as possible and use tie wrap to secure.

Duct section D is not supplied with unit. Must be 200mm Ø insulated.

Duct section B is not supplied with unit. Must be 200mm Ø insulated.

Duct section C is not supplied with unit. It is used to draw air in from high level in the loft in a "cold roof" or via the tiles/slates in a "warm roof". (See diagram above for details). Duct must be 200mm Ø uninsulated.

Duct section E is not supplied with unit. It is used to draw air into the system from outside (see diagrams below for details) Main duct must be 200mm Ø insulated.

Slave

Master

See sections 2.4 and 2.5

Via a wall grille and ducting

supplied by the installer

200mm dia. insulated ducting connected to unit spigot using dynotie connector.

199 x 215 x 20mm white plastic wall grille (Part No. SAVD6-EG).

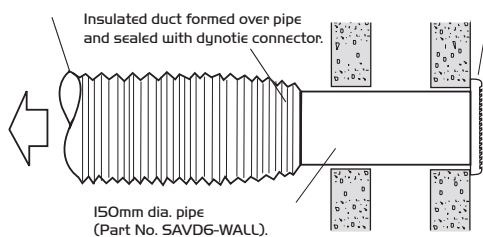

Via the soffit through a grille and ducting

supplied by the installer

Circular duct connector (Part No. FDC200).

222mm x 90mm flexible PVC Rectangular ducting (Part No. PVC933WH) Note: this duct should be left as short as possible.

200mm dia. insulated ducting connected to unit spigot using dynotie connector.

Form end of rectangular ducting to fit connector and secure using dynotie connector.

Soffit grille (Part No. 518920) fixes over rectangular ducting which has been pulled through rectangular hole (220mm X 80mm) cut in soffit and folded flat up against the surface of the soffit. Note that a minimum soffit width of 130mm is required.

2.0 Installation of the 3 part Air Handling Unit and Associated Components

Note: Regarding Ducting. The following installation materials, not supplied with the unit, can be purchased separately by the installer direct from Nuair's distributor, Fans Direct. Tel: 08705 121400 Fax: 08705 121444
E-mail: info@fansdirect.co.uk

Part No	Description
PVC 933WH	3m length of 222mm x 90mm flexible PVC ducting for use on soffit inlets. This length should be sufficient for 3 average installations.
518920	128mm x 260mm soffit grille.
FDC 200	200mm duct connector for connecting 222 x 90 flexible duct to 200 dia. insulated duct.
SAVD6-EG	199 x 215 x 20mm white plastic wall grille.
SAVD6-WALL	150mm dia. pipe for wall grille.
541044	Dynotie Zip ties, used for connecting 200mm ducting to spigots. 8 off should be sufficient for all types of installation.
FLDI 200	5m length of 200mm dia. insulated ducting.
FLD 200	5m length of 200mm dia. un-insulated ducting.
O11740	200mm dia. outlet spigot. For use with "Fireblock".

2.4 Supply Air Diffuser

The diffuser has a unique air throw pattern and it must be located correctly in the central hallway in single storey properties or in the ceiling of the top floor landing on 2 or more storey dwellings.

The diffuser discharges air from all four sides along the underside of the ceiling (figure 4). The majority of the air is discharged through the two longer open sides and it is vital that the diffuser is positioned to ensure these two sides discharge the air down the longest lengths of the hallway or landing. Obstructions within 1m of the diffuser will cause a poor airflow pattern and unacceptable draughts. Up to two sides of the diffuser may be closed off using the foam strips supplied.

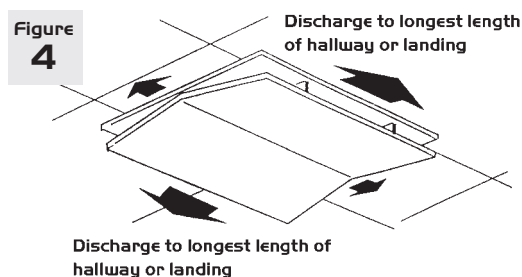

2.5 Fitting the Diffuser

Cut a circular hole 225mm diameter in the ceiling between two joists. Position the diffuser frame and secure to the underside of the ceiling with the 1 1/2" x 8 csk screws and plugs provided.

Attach the diffuser plate to the frame using the two 1" x 8 csk screws provided. (See figure 5).

Note: Smoke Detectors

It is important that any open side of the diffuser is not positioned within 1m of a smoke detector.

If the diffuser cannot be repositioned, up to two sides of the diffuser may be closed off using the foam strips supplied so that the open sides face a minimum 1.5m unobstructed path away from the detector.

As an alternative to the aforementioned, a smoke detector maybe fitted directly onto the underside of the diffuser.

Figure 5

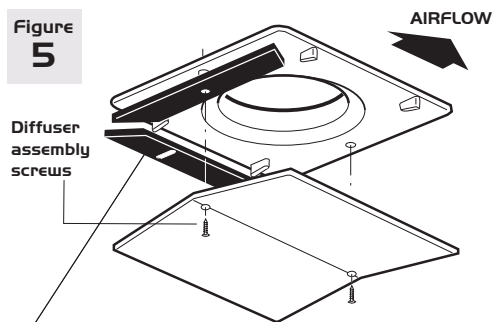

Foam strip being used to guide airflow away from a smoke detector and/or obstructions as required (See notes)

The strips will fit on any side. Simply remove the relevant 'pushouts' provided in each strip

Where there is a requirement for maintaining fire rating of the ceiling then the following alternative method of installing the diffuser using a 200mm dia. spigot available from Nuair and a "Fireblock" is recommended. (See figure 6).

Designed to provide 1 hour of fire resistance in accordance with BS476 Part 20 (1987) and ISO 834, this circular "Fireblock" is available to fit snugly inside our standard 200mm dia. spigot. (Part No. O11740).

Figure 6

"Fireblock" Standard "V" 195 mm outside dia. available from Dufaylite (See website www.dufaylite.com) fits inside of spigot and retained by self tapping screws supplied by the installer

Screw bottom part of diffuser to the ceiling via plastic spacers supplied by the installer

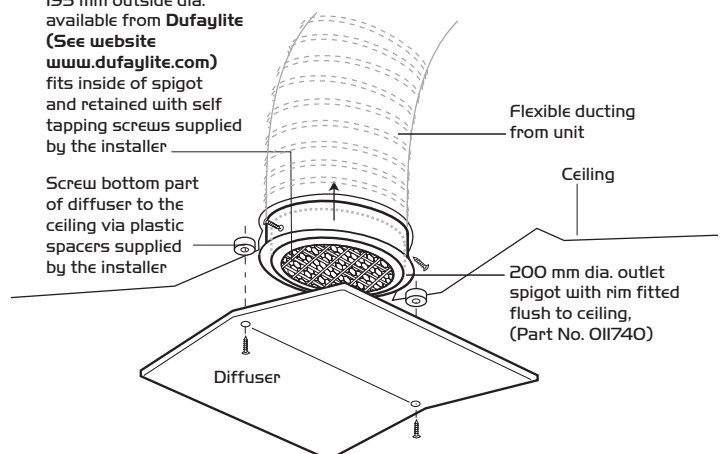

Foam strips should also be used as required when this method of installing the diffuser is used.

2.0 Installation of the 3 part Air Handling Unit and Associated Components

2.6 Temperature Sensor Locations

Correct location of the sensors is essential for the correct operation of the system. Follow the instructions in figure 7 exactly. These connections are low voltage. All sensors must be connected to their respective marked terminal on the air handling units. Failure to do so will prevent the system from working correctly.

Figure
7

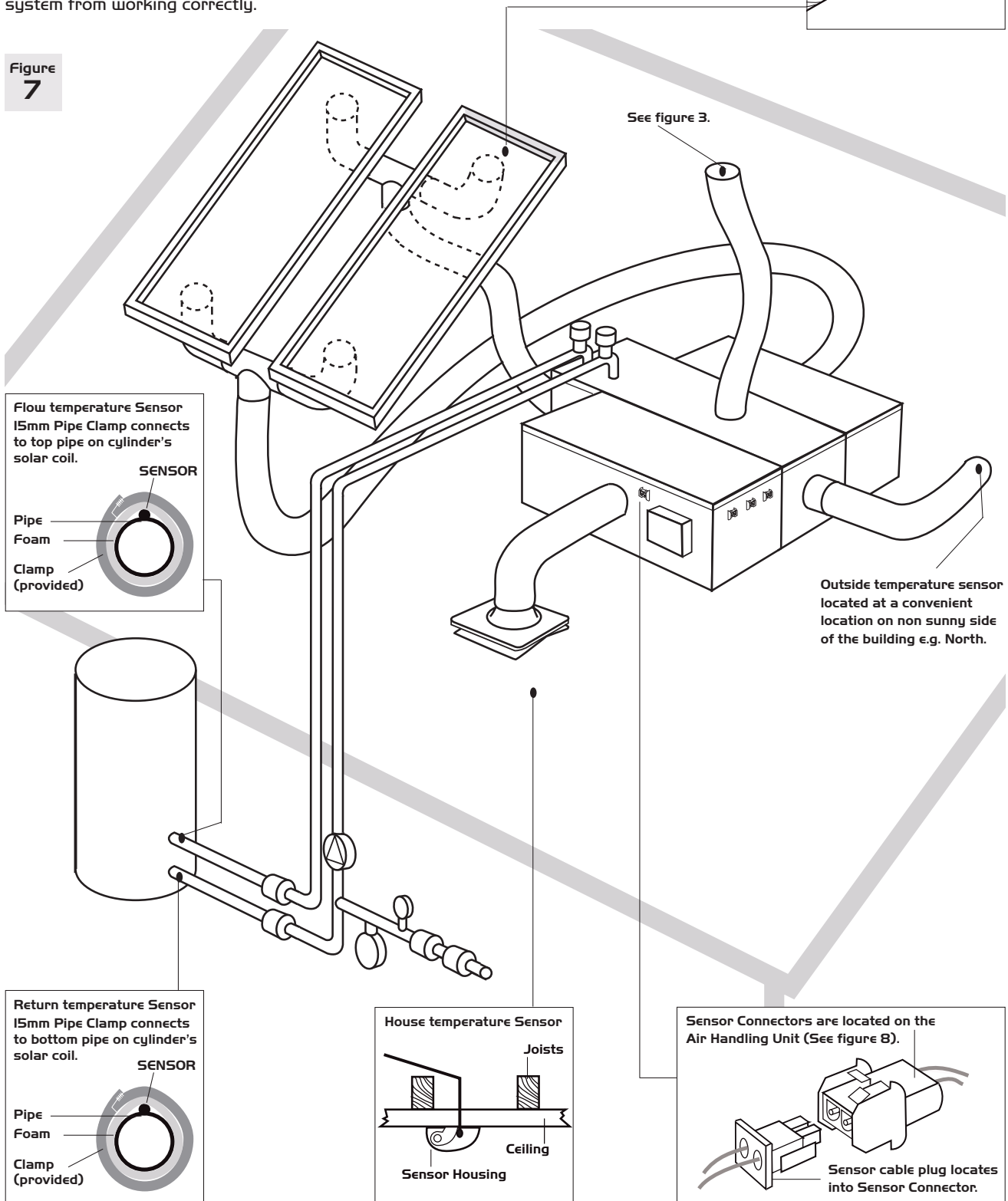

2.7 Temperature Sensor Connections to Air Handling System

Each sensor has its own specific connector located and marked on the Air Handling units. It is essential that figure 8 is followed exactly.

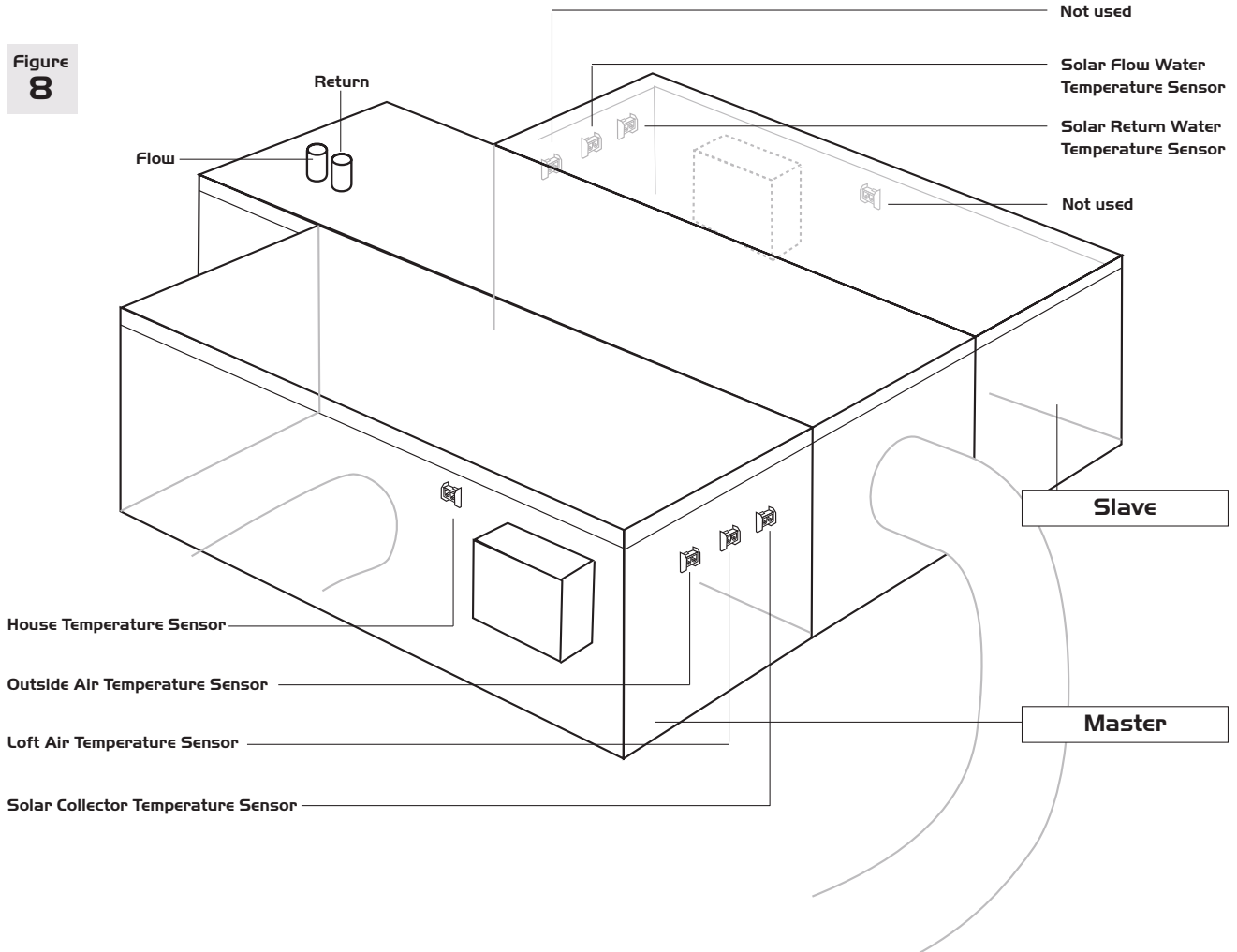

3.0 Installation of the Solar Hot Water Storage System and Associated Components

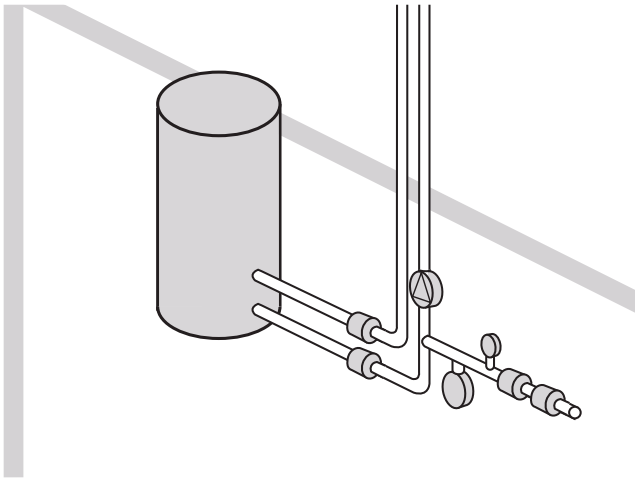

Sunwarm can be integrated with a wide range of solar hot water storage systems. These devices can be purchased through Sunwarm International or be supplied by others. For best energy gain we would recommend a well insulated hot water cylinder with a high efficiency solar coil at the lowest part of the cylinder.

For Solar Hot Water Connections refer to figure 9 and the key to components below. Please note all the items listed below form the Solar Loop Kit supplied as an option.

Number	Description
1	3 bar pressure relief valve
2	Air eliminator with Shut off valve
3	2 x 22 x 1/2 inch x 22 compression tee fittings
4	3/4 BSP X 15mm addaptor
5	Expansion vessel 8 litres
6	Expansion vessel bracket
7	2 x No. 12 rawl plugs
8	Combi filling loop
9	3.5 bar pressure gauge
10	15 x 15 x 1/2 inch comp. tee
11	Grundfos 25 - 15 circulator pump
12	2 x 22mm pump isolating valves
13	15mm non return valve
14	4 x 22 x 15 reducer sets
15	Drain cock
16	1/2 inch x 1/4 inch BSP reducing bush
17	PTFE tape (Use only on threaded parts)
18	2 x 15 x 15 x 15 T piece
19	2 No. 10 Posi screws

Figure 9

Typical pipe work connections.

Air to water heat exchanger, part of the Air Handling Units.

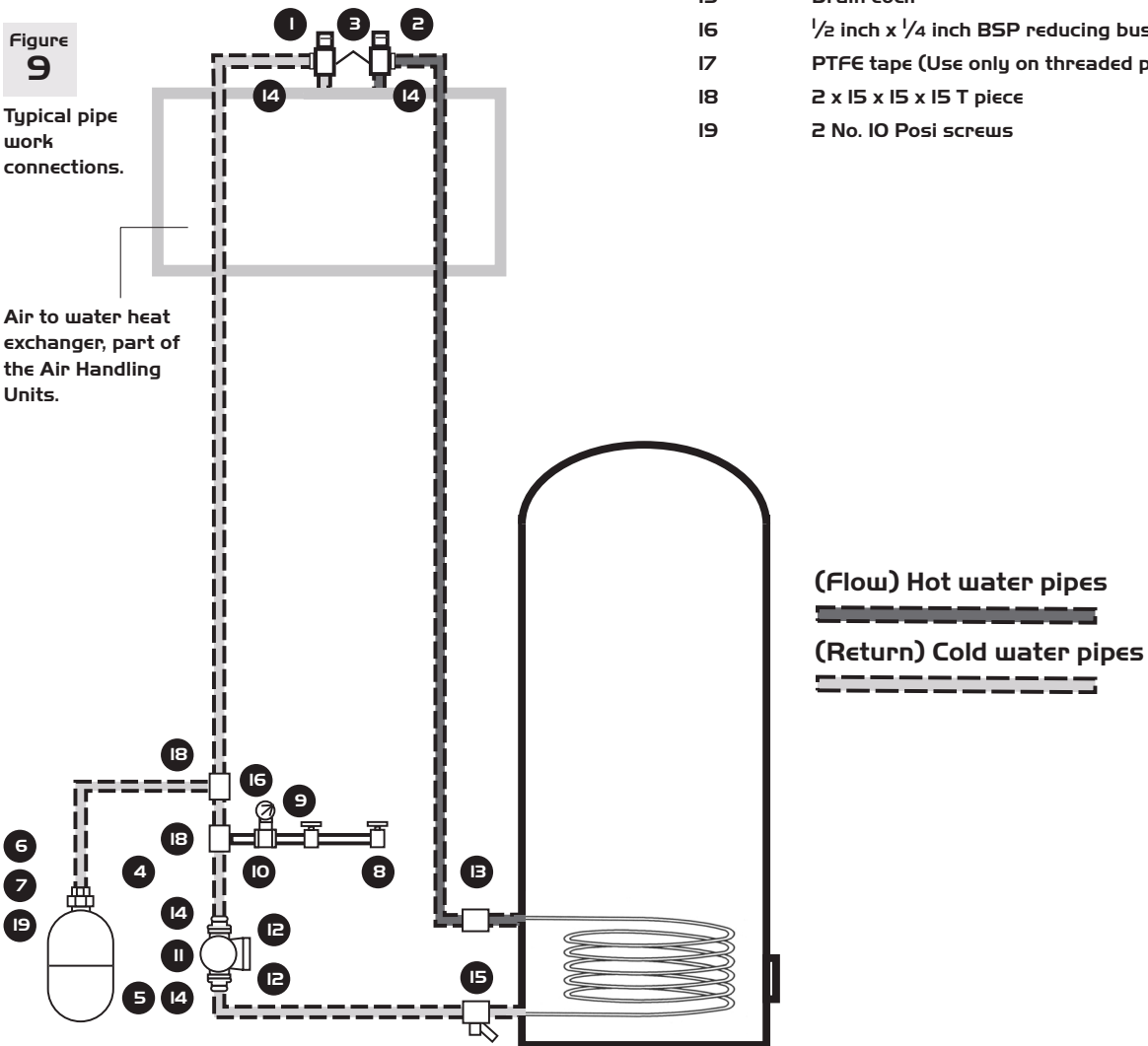

(Flow) Hot water pipes
 (Return) Cold water pipes

4.0 Electrical Connections

4.1 Wiring

Please note: the electrical connection of the unit must be carried out by a qualified electrician.

Electrical details:-

Voltage: 240V 1ph 50Hz

Consumption: 40W (max)

Fuse rating: 3 Amp

NOTE This unit must be earthed.

The three core cable from the mains power supply should be connected to a fixed wiring installation, via a fused isolator, in accordance with current IEE wiring regulations.

LV = Low Voltage Net cable supplied.

Figure
10

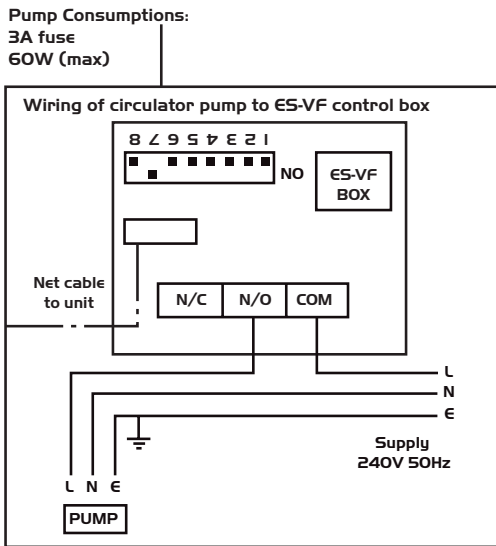

This connection may be to the slave unit if required.

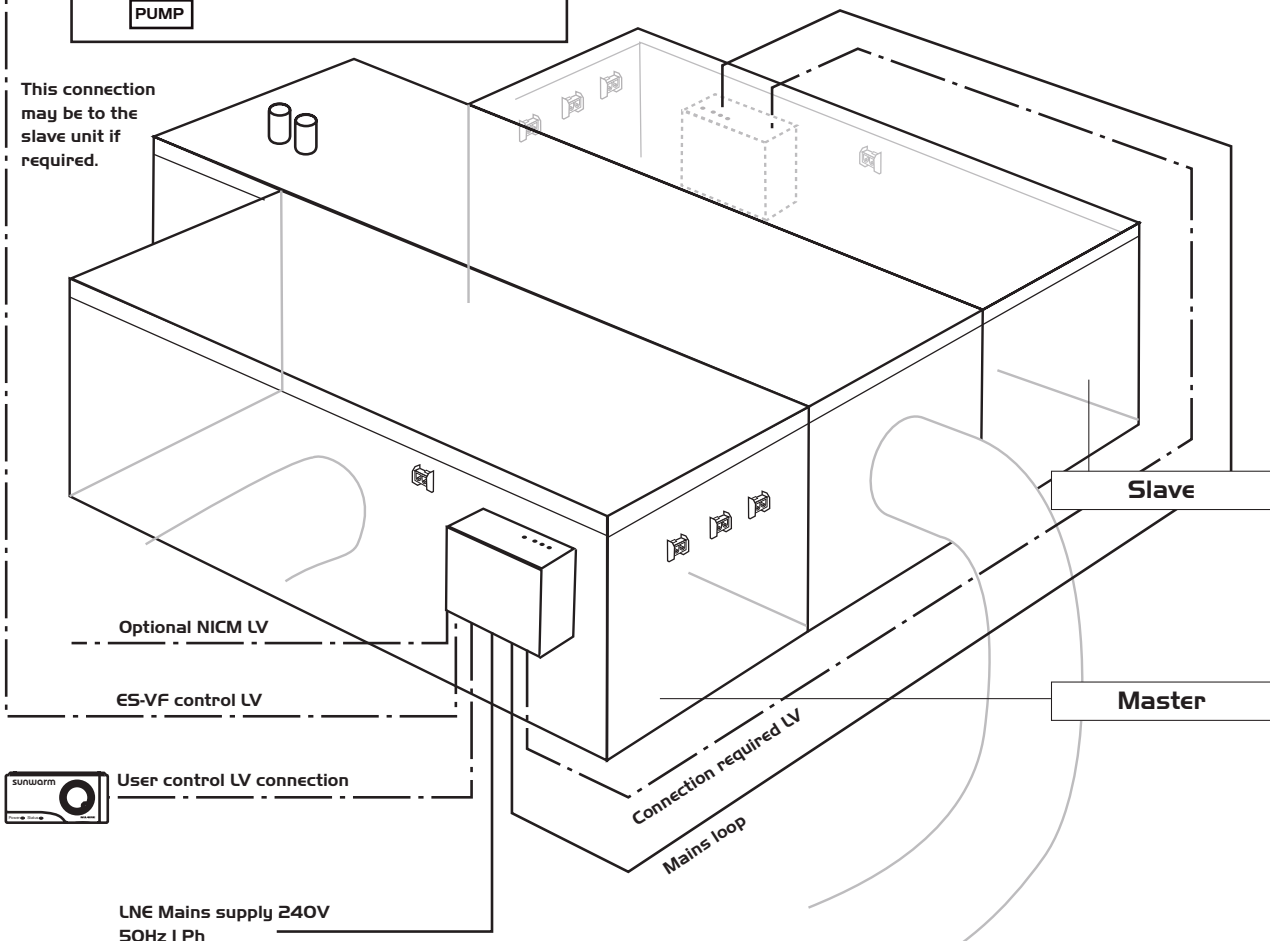

IMPORTANT NOTE

Turn power supply off before connecting the optional NICM Unit. Failure to do so will damage the unit and render the warranty void.

4.0 Electrical Connections

4.2 User Control

The user control should be fitted to an appropriate wall (fixings supplied). Position the control so that the user can gain easy access. Instructions for fixing are supplied with the control.

Screw the backplate to the wall. Connect the cable (supplied) and clip the control into place. Route the cable to the loft and connect to the main unit control module panel. Secure the cable to prevent accidental dislocation.

Figure 11

User control cover closed

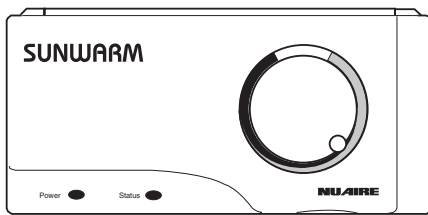

User control cover open

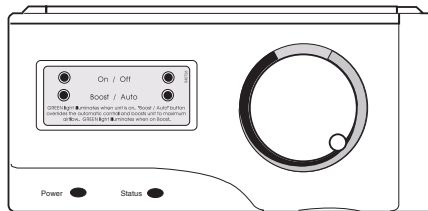

User Control Test

Ensure the power light is on green and the status light is either green or amber.

If the power light is not on check the wiring and connections between the fan unit and the user control.

Sunwarm User Control

The user control as shown in figure 11 above, has a target temperature setting dial and two press buttons (under the flap) which enable the fan to be switched off or the airflow to be boosted to its maximum duty.

Figure 12

Master Control Unit (cover removed).

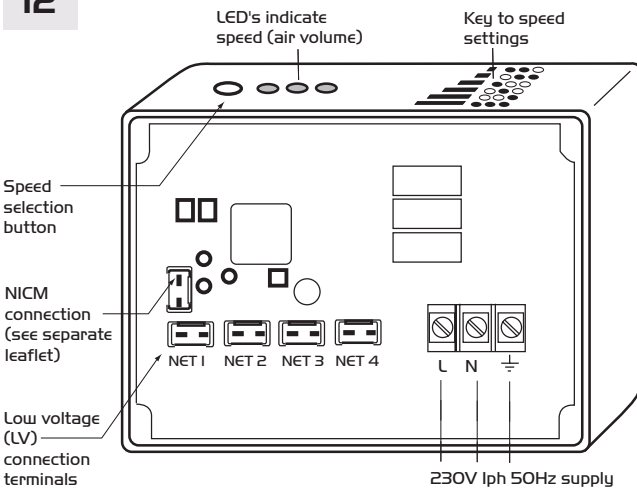

4.3 Airflow Adjustment on Master Unit

The unit has six air volume (speed) settings. The setting switch is located on the main control box on the fan case.

Figure 12 shows the LED's that, when illuminated, indicate the corresponding air volume for the unit.

For example, a one bedroom, one person bungalow would be adjusted to the lowest setting (two LED's on the left illuminated).

A five bedroom seven person detached house would need to be set to the highest (all three LED's illuminated).

With power connected the three LED's will flash randomly for approximately 2 minutes and will then indicate the speed currently set. To select another speed, simply continue to press the button down until the required setting is shown.

Default setting on Master Unit is middle LED on (40l/s flow rate).



on Slave Unit outer LED's should be on.







(Please note Slave Unit is not adjustable.)



4.4 Trouble Shooting

If there are any red lights flashing on either the master or the slave unit consult the following table to determine the cause.

On Master Unit :

Outside sensor not connected	
House sensor not connected	
Collector sensor not connected	
Loft sensor not connected	

On Slave Unit:

Solar return sensor not connected	
Solar flow sensor not connected	



5.0 Commissioning the System, checklist

It is recommended that the optional NICM Unit be used in the real time monitor mode for commissioning of Sunwarm. This will save substantial time and is more accurate than a visual inspection.

Ref code	Item Documentation	Yes	No	N/A	Notes
Doc 1)	Documentation left with building occupier 1) User manual 2) Installation & maintenance				
Doc 2)	Solar system commissioning certificate completed and signed				
Doc 3)	Cylinder/store commissioning certificate completed and signed (if store replaced)				
Doc 4)	DHW drain location and DHW isolation points pointed out				
Doc 5)	System schematic drawing (mechanical and electric) Pointed out				
Doc 6)	Specialist maintenance tasks, schedule and parts list Filter Pressure				
Doc 7)	Manual DHW drain-off method to prevent over-heating is prescribed and safe (if required)				
Doc 8)	User actions to prevent freeze damage to be stated				
Doc 9)	De-commissioning method including any hazardous substances to be stated				
Doc 10)	All end-user and manufacturer's instructions for all installed solar water heating equipment shown and explained to end-user. Document storage location to be explained				
Doc 11)	Where required by PED (pressure has potential to exceed 0.5 bar and temperature over 110°C), evidence left on site of compliance with essential safety requirements with CE mark				
Doc 12)	Manufacturer's written installation requirements to be left on-site for any fitted electrical and mechanical equipment.				
Doc 13)	Hot water store listed as approved by Clear Skies Labelling and type of replacement store to building regulations				
Doc 14)	System Registration documented on page 20				

5.0 Commissioning the System, checklist

Ref code	Item	Yes	No	N/A	Notes
	Electrical				
Elec 1)	Check all electrical connections per figure 10				
Elec 2)	240V isolation switch and fuse protection fitted				
Elec 3)	Class I equipment such as pumps etc is earthed				
Elec 4)	All wiring supported and routed reasonably and of correct length				
Elec 5)	Cable to pump is heat resisting flex				
Elec 6)	All cabling correct current rating, type and suitable for purpose				
Elec 7)	Cable sheaths taken into enclosures and glands				
Elec 8)	All connections are enclosed				
Elec 9)	Check all sensor connections per figure 8				
Elec 10)	Check solar flow sensor to be close to tank				
Elec 11)	Check solar return sensor to be close to tank				
Elec 12)	LV and 240V wires are min 5cm apart				
	Roof				
Roof 1)	Collector appearance OK				
Roof 2)	No significant shading across collector				
Roof 3)	Collector orientation checked with that on application				
Roof 4)	Auto air vent not obstructed				
Roof 5)	Roof fixings robust and weather tight. Roof penetrations i.e. sarking felt made good				
Roof 6)	Collector mountings solid				
	Operation				
Oper 1)	LED'S on user control are correct pattern				
Oper 2)	Electrical controls and sensors are operating				
Oper 3)	Reverse flow protection identifiable from schematic				
Oper 4)	If a hot water store does not have an open vent then a combination of thermostatic control device, energy cut-off device and heat dissipation method should be present. (i.e. unvented stores and sealed thermal stores)				
Oper 5)	If a hot water store has an open vent it must have at least a thermostatic control or a temperature relief valve				
Oper 6)	All safety devices to operate correctly				
Oper 7)	Check for excessive pump noise				
Oper 8)	Check ventilation units, correct set up (Master/Slave)				
Oper 9)	Sufficient expansion capability in cisterns and vessels				
Oper 10)	Check all ductwork, connections and type				
Oper 11)	Check for fan noise				
Oper 12)	Check diffuser location				

5.0 Commissioning the System, checklist

Ref code	Item General	Yes	No	N/A	Notes
Gen 1)	Prevention of water backflow into potable rising main by check valve. Filling loop is disconnected				
Gen 2)	Sufficient drain points - to enable all pipes to be drained				
Gen 3)	Materials are rated and WRAS listed at stagnation temperature and pressure				
Gen 4)	Open vent termination over correct cistern				
Gen 5)	No obstruction before safety valves or vents. Vents and discharge pipes to be correctly graded and exhaust locations are safe - no scald risk to people				
Gen 6)	Sound engineering practice to be used or evidence left on site of higher conformity according to PED. All pressure components to be labelled and identifiable				
Gen 7)	Pipe clips and insulation to be sufficient for stagnation temperatures				
Gen 8)	All indoor components in unheated areas to be sufficiently protected from freeze damage				
Gen 9)	Anti scald measures are in place e.g. controller can be set or auto blend valve is fitted				
Gen 10)	Pressure relief measures will operate before failure risk of most vulnerable component				
Gen 11)	If replaced, DHW back-up heat source to have time switch				
Gen 12)	If replaced, DHW back-up heat source to have correctly located thermostat and interlock				
Gen 13)	On replacement cylinders, all connected pipes to be insulated where practicable				
Gen 14)	Hot water store sufficient and dedicated pre-heat volume for user requirements				
Gen 15)	Hot water store sensor pockets or digital readout				
Gen 16)	Check auxiliary heat source is capable of heating store to at least 55°C to prevent leg ionella				
Gen 17)	All unions, and glands are free from leaks; no leaking evident elsewhere e.g from pipework joints etc.				
Gen 18)	All pipework is adequately clipped, insulated and components are adequately supported				
Gen 19)	Pipe insulation to be firmly in place and secured at junctions and corners				
Gen 20)	Penetrations in building made good. Debris removed				
Gen 21)	Check solar loop pressure is 1 to 1.5 bar				
Gen 22)	Increase solar loop pressure to test relief valve				
Gen 23)	Check plumbing components per figure 9				

Notes: 1) if NICM is used “-1” reading on any sensor indicates possibility of no connection.

2) to turn the pump on manually, on the ES-VF (Pump) box turn switch 8 on. Make sure you return it to off when testing is finished.

6.0 Dimensions of the System Components

Figure 13 Dimensions for the 3 part Air Handling Unit (mm).

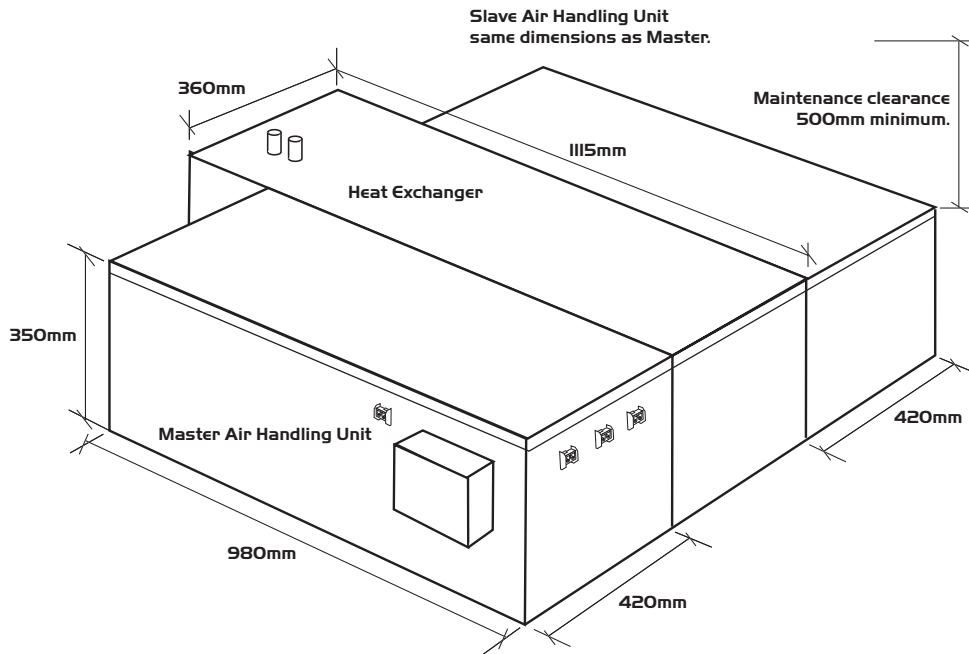
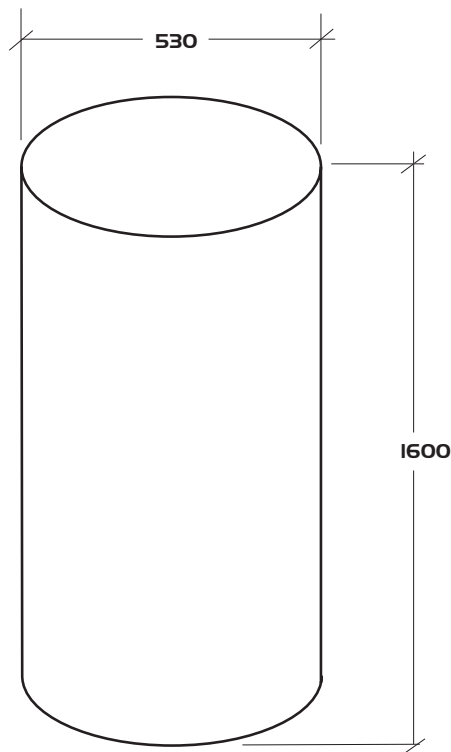

Figure 14 Typical Hot Water Cylinder (note: exact size should be confirmed with Nuair).



7.1 Maintenance Notes

The unit does not require any maintenance other than a filter change and a check of electrical connections every 5 years. However, the system pressure in the hot water pipework should be regularly checked as per section 7.3. The status light on the user control panel will flash red when a filter change is required.

New filters can be purchased direct from Nuairé using the following code: O4O718 (5 year filter).



If the status light is permanently red, or if the units performance has been reduced dramatically and there is no flashing red light, please contact our service department or your installer.

Dust can occasionally accumulate through static, on the diffuser and the adjacent ceiling. This can be removed if required by vacuuming.

Note: A clear distance of 500mm should be available above the unit to allow access for maintenance.

7.2 Filter Change

Once every 5 years the status LED on the main user control will flash red. This indicates filters need changing.

- a) Make sure power to the unit is off.
- b) Open the lid of the Air Handling Units by removing the 6 screws which hold the lid on.
- c) Remove the 2 filters in each Air Handling Unit by pulling them away from the rim. (green fan housing).
- d) Replace the filters by pushing the metal rim into the slots on the green fan housing.
- e) Repeat for the other Air Handling Unit.
- f) Replace and secure the lids.
- g) Reset the LED light that was flashing, by:
 - i) Turn the power to the unit on.
 - ii) Press and hold the black push button switch on master control switch.
 - iii) A number of LED patterns will show.
 - iv) When    shows up release the button.
ON OFF OFF
 - v) The led light should now be reset.

7.3 System Pressure

- a) Regularly check the Pressure Gauge of the system (normally connected near the filling loop).
- b) If the black indicator is below the red marker, connect the filling loop and open the valve very gently for a very short duration, until the black hand is just past the red one, turn off the valves and disconnect the filling loop.

8.0 Warranty

The units 5 year warranty starts from the day of delivery and includes parts and labour. (All components manufactured by Nuairé). Circulator pump and hot water cylinder are covered by their respective manufacturer's warranty.

9.0 Service Enquiries

Service issues can be handled by your installer or Nuairé. Our service department will be happy to provide any assistance required, initially by telephone and if necessary arrange for an engineer to call.

Telephone 029 2085 8441

10.0 Certification

Nuairé certifies its products to meet all applicable local and national laws; however, installation must also be in accordance to the applicable laws. Some general guidelines are provided on page 18.

11.0 NICM

Non-intrusive Control and Monitoring. This device allows for remote downloading of information logged by the system. Follow the instruction provided with the product, or simply turn the power to the entire unit off. Remove the cover of the control box (see figure 12) and connect the plug of NICM to the appropriate connector plug shown. Replace the cover and turn power back on. In order for this system to work, the other part must be connected to a PC, or laptop (within 30m of the unit) and the accompanying software fully installed, as explained in the leaflet supplied with the unit.

For installation of Solar Air Collectors (see Sunwarm and Ecosun Solar Air Collectors Application and Installation Guide, leaflet number 671274).

DECLARATION OF INCORPORATION AND INFORMATION FOR SAFE INSTALLATION, OPERATION AND MAINTENANCE

We declare that the machinery named below is intended to be assembled with other components to constitute a system of machinery. The machinery shall not be put into service until the system has been declared to be in conformity with the provisions of the EC Council Machinery Directive.

Designation of machinery: **SUNWARM**
 Machinery Types: **SUNWARM**
 Relevant EC Council Directives: **98/37/EC (Machinery Directive)**
 Applied Harmonised Standards: **EN292-1, EN292-2, EN294, EN29001**
 Applied National Standards: **BS848 Parts One, Two and Five**

Signature of manufacture representatives:



Name:	Position:	Date:
1) C. Biggs 	Technical Director	23.12.02
2) W. Glover 	Manufacturing Director	23.12.02

CE DECLARATION OF CONFORMITY

We declare that the machine named below conforms to the requirements of EC Council Directives relating to Electromagnetic Compatibility and Safety of Electrical Equipment.

Designation of machinery: **SUNWARM**
 Machinery Types: **SUNWARM**
 Relevant EC Council Directives: **89/336/EEC, 92/31/EEC (EMC)
 73/23/EEC, 93/68/EEC (Low Voltage Directive)**
 Applied Harmonised Standards: **EN55014-1, EN55014-2, EN60204-1
 EN60335-2-80**
 Basis of Self Attestation: **Quality Assurance to BS EN ISO 9001
 BSI Registered Firm
 Certificate No. FM 149**

Signature of manufacture representatives:

Name:	Position:	Date:
1) C. Biggs 	Technical Director	23.12.02
2) W. Glover 	Manufacturing Director	23.12.02

INFORMATION FOR SAFE INSTALLATION, OPERATION AND MAINTENANCE OF NUAIRE VENTILATION EQUIPMENT

To comply with EC Council Directives 98/37/EC Machinery Directive

To be read in conjunction with the relevant Product Documentation (see 2.1)

1.0 GENERAL

- 1.1 The equipment referred to in this Declaration of Incorporation is supplied by Nuaire to be assembled into a ventilation system which may or may not include additional components.
 The entire system must be considered for safety purposes and it is the responsibility of the installer to ensure that all of the equipment is installed in compliance with the manufacturers recommendations and with due regard to current legislation and codes of practice.

2.0 INFORMATION SUPPLIED WITH THE EQUIPMENT

- 2.1 Each item of equipment is supplied with a set of documentation which provides the information required for the safe installation and maintenance of the equipment. This may be in the form of a Data sheet and/or Installation and Maintenance instruction.
 2.2 Each unit has a rating plate attached to its outer casing. The rating plate provides essential data relating to the equipment such as serial number, unit code and electrical data. Any further data that may be required will be found in the documentation. If any item is unclear or more information is required, contact Nuaire.
 2.3 Where warning labels or notices are attached to the unit the instructions given must be adhered to.

3.0 TRANSPORTATION, HANDLING AND STORAGE

- 3.1 Care must be taken at all times to prevent damage to the equipment. Note that shock to the unit may result in the balance of the impeller being affected.
 3.2 When handling the equipment, care should be taken with corners and edges and that the weight distribution within the unit is considered. Lifting gear such as slings or ropes must be arranged so as not to bear on the casing.
 3.3 Equipment stored on site prior to installation should be protected from the weather and steps taken to prevent ingress of contaminants.

4.0 OPERATIONAL LIMITS

- 4.1 It is important that the specified operational limits for the equipment are adhered to e.g. operational air temperature, air borne contaminants and unit orientation.
 4.2 Where installation accessories are supplied with the specified equipment eg. wall mounting brackets. They are to be used to support the equipment only. Other system components must have separate provision for support.
 4.3 Flanges and connection spigots are provided for the purpose of joining to ductwork systems. They must not be used to support the ductwork.

5.0 INSTALLATION REQUIREMENTS

In addition to the particular requirements given for the individual product, the following general requirements should be noted.

- 5.1 Where access to any part of equipment which moves, or can become electrically live are not prevented by the equipment panels or by fixed installation detail (eg ducting), then guarding to the appropriate standard must be fitted.
 5.2 The electrical installation of the equipment must comply with the requirements of the relevant local electrical safety regulations.

6.0 COMMISSIONING REQUIREMENTS

- 6.1 General pre-commissioning checks relevant to safe operation consist of the following:
 Ensure that no foreign bodies are present within the fan or casing.
 Check electrical safety. e.g. Insulation and earthing.
 Check guarding of system.
 Check operation of Isolators/Controls.
 Check fastenings for security.
 6.2 Other commissioning requirements are given in the relevant product documentation.

7.0 OPERATIONAL REQUIREMENTS

- 7.1 Equipment access panels must be in place at all times during operation of the unit, and must be secured with the original fastenings.
 7.2 If failure of the equipment occurs or is suspected then it should be taken out of service until a competent person can effect repair or examination. (Note that certain ranges of equipment are designed to detect and compensate for fan failure).

8.0 MAINTENANCE REQUIREMENTS

- 8.1 Specific maintenance requirements are given in the relevant product documentation.
 8.2 It is important that the correct tools are used for the various tasks required.
 8.3 If the access panels are to be removed for any reason the electrical supply to the unit must be isolated.
 8.4 A minimum period of two minutes should be allowed after electrical disconnection before access panels are removed. This will allow the impeller to come to rest.
NB: Care should still be taken however since airflow generated at some other point in the system can cause the impeller to "windmill" even when power is not present.
 8.5 Care should be taken when removing and storing access panels in windy conditions.

Technical or commercial considerations may, from time to time, make it necessary to alter the design, performance and dimensions of equipment and the right is reserved to make such changes without prior notice.



**SOLAR SYSTEM
COMMISSIONING CERTIFICATE**

Sunwarm International, a division of Nuaire Ltd, confirms that the installation of this Sunwarm System – serial no. _____ meets all necessary manufacturer requirements and applicable laws.

Signature of Authorised Commissioning Officer,

_____ Date _____





II.O System Registration

Name of owner: _____

Address: _____

Installer Contacts: _____

Date Installed: _____

Collector Serial No. 1) _____

2) _____

**Master Controller
Serial No.** _____

Fan Speed set to: _____

Pump Speed set to: _____

www.sunwarm.com

Your local Sunwarm representative.

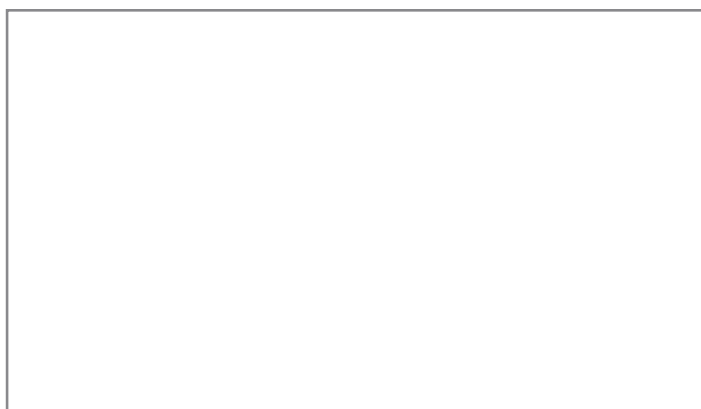

Nuaire Limited. • Western Industrial Estate • Caerphilly • CF83 1NA • United Kingdom

Manual Number: 671275 January 05